

PART	DESCRIPTION
U1-U2	MC34074P
U3	EP1017
U4	ULN2004A
U5-U6	WO2M
U7	LM78L12ACH
CR1	1N4744A 15V
CR2	1N5241B 11V
CR3-CR6	IN4004
PM1-PM4	EP1024-0
T1	EP1031A(120/240), EP1030(120)
T1	EP1031-1(240), EP1032A(240/480)
CP1-CP2	PCB-2
RN1	750-63-R10k
RN2	750-83-R47K
RN3	750-83-R47k
RN4	750-103-R1.5k
RN5	750-83-R10k
RN6	750-83-R47k
RN7	750-83-R22k
C1	ECEA1HV475S
C2	ECS-F16E22
C3	ECS-F16E2R2
C5-C6	MKC4 .33μF 10%
C7	FKS3 680pF 5%
C8	FKS3 3300pF 10%
C9	MKS3 .68μF 10%
C10	MKS3 .068μF 10%
C11	MKS02 or ECS-F1CEXXXK(15)
Q1-Q2	2N2222
R1-R3	3W 220 5%
R4	5W XXX 5% (8)
R5	3W XXX 5% (12)
R6	93PR 5K
R7	93PR 5K
R8	CW-2C 10
R11-R31	RN60 1/4W 1% (9) (10)
PD1	LN21RPH (RED)
PD2	LN31GPH (GRN)
P1-P4 SOCKETS	350689-3 (BRZ, AWG 24-18)
J1/P1	1-350945-0 / 350809-1
J2/P2	640583-1 / 640581-1
J3/P3	1-350945-0 / 350809-1
J4/P4	350713-1 / 350735-1
J5/P5	350792-1 / 350779-1
J6	1-640452-4
J7/P7	640456-6 / 640440-6
J8/P8	640454-3 /

RN60 RESISTOR SELECTION (k)					
R11	(3)	R17	.806	R23	2.00
R12	(4)	R18	20.0	R29	2.67k
R13	191	R19	4.99	R30	0.00k
R14	(6)	R20	7.50	R31	47.5k
R15	(7)	R21	3.01		
R16	4.99	R22	750		

NOTES

- Adjust R6 (BIAS) for 0% SCR output with SIG HI = 0 Vdc.
- Adjust R7 (SPAN) for 100% SCR output with SIG HI = 5.0 Vdc.
- Install R11 = 249 for 20 mAdc current signal input.
- Factory selected resistance.
- For 50 Hz operation: move P8 jumper to "50 Hz" position.
- Select R14 for desired soft-start time.
- Select R15 for desired soft-stop time.
- Select R4 for 1.0 Vdc full load feedback signal.
- For open loop operation: Omit U5 & R4, Jumper pins 3&4 OF J6, Make R31 = 47.5k, Select C9 for desired bandwidth.
- For current regulation only: Omit regulator board, Jumper pins 3 & 4 of J6, Select R31 resistance for desired regulator stiffness, Select C9 capacitance for adequate regulator stability margin.
- For two SCR operation: omit C5, R3, J2, PM3, and PM4.
- Select R5 resistance for desired lamp or relay coil voltage.
- Table shows jumper connections 2 or 4-quadrant operation. Cut trace where indicated for 4-quadrant operation.
- For dc feedback signal, omit U5 and jumper U5 pads 1 & 4, 2 & 3.
- Optional capacitor C11 to increase gate delay response time.
- Cut trace where indicated when VRCL1P-1 board is installed

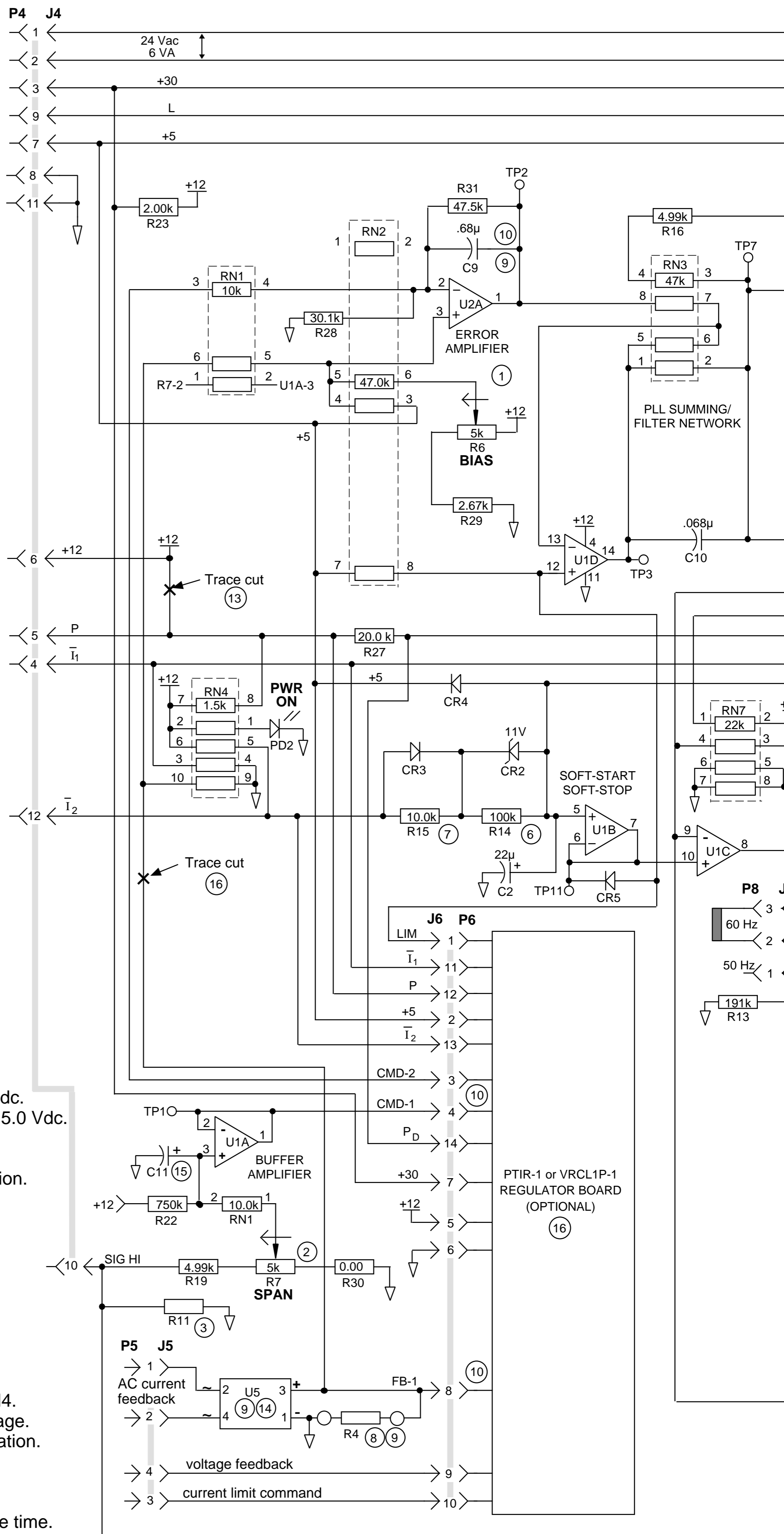

SERIAL NOS.

E168 Rev. K

REVISIONS

LTR	DESCRIPTION	DATE	APPD
J	Add R29, R30, & R31. Change PM1 - PM4	7-15-99	web
K	Corrected artwork.	12-8-99	ppd

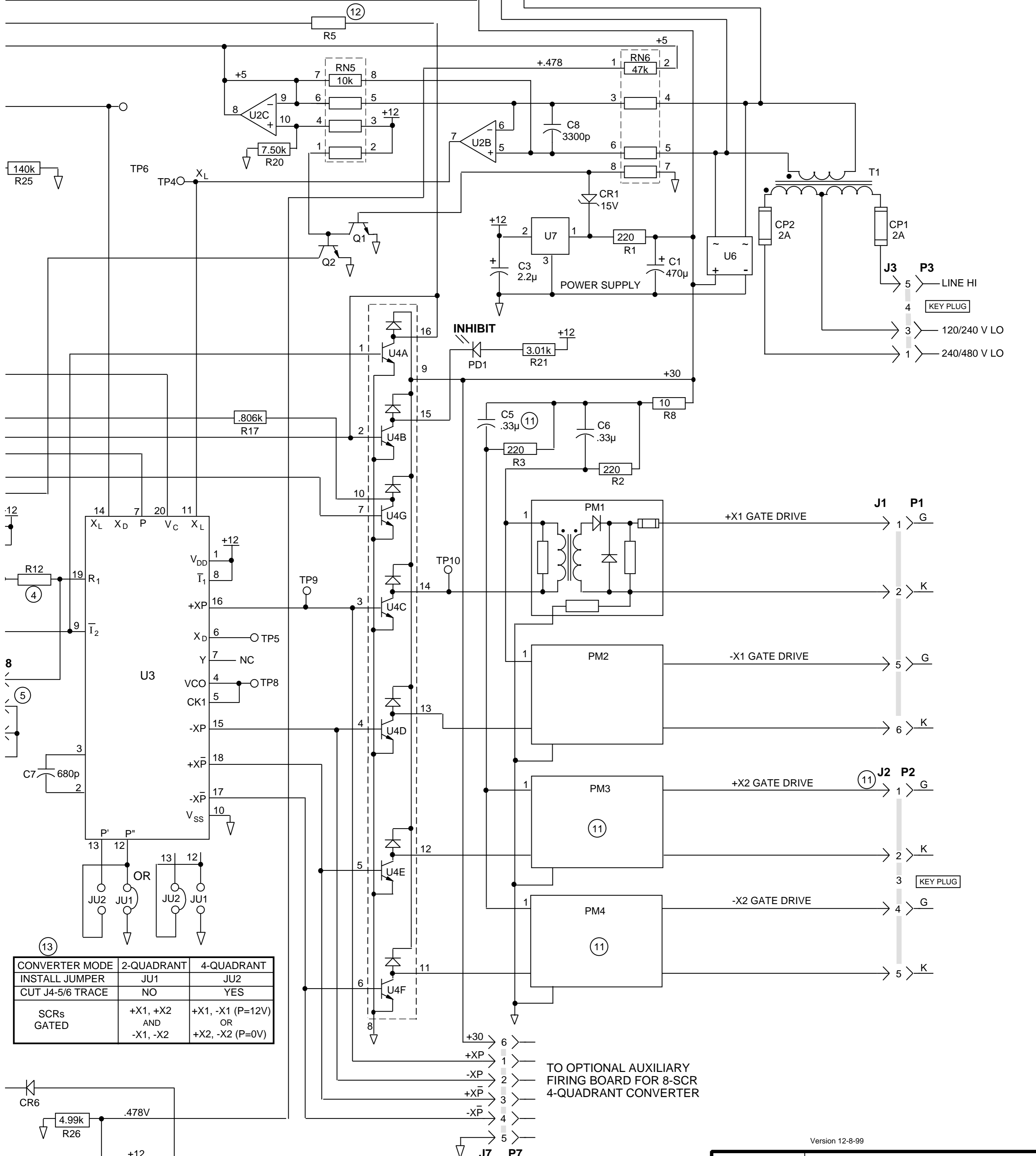

CONVERTER MODE	2-QUADRANT	4-QUADRANT
INSTALL JUMPER	JU1	JU2
CUT J4-5/6 TRACE	NO	YES
SCRs GATED	+X1, +X2 AND -X1, -X2	+X1, -X1 (P=12V) OR +X2, -X2 (P=0V)

TO OPTIONAL AUXILIARY FIRING BOARD FOR 8-SCR 4-QUADRANT CONVERTER

Version 12-8-99

ENERPRO		SINGLE PH. 4-SCR BIPOLAR FIRING CIRCUIT/REGULATOR	
Approvals	Date	PWA PART NO. FCR04100	Dwg No. E168
drawn: fjb	11-28-84		
redrw. cja	8-4-87		
chk'd: web	6-21-88		
chkd: yas	1-25-93		