

REVISIONS				
DATE	LTR	DESCRIPTION	ECO	APPD
11-25-98		Drafted	--	ppd
5-15-99	A	Add external current command capability for the 2nd production run	--	fjb

- NOTES:**
- For current signal input:
 - Jumper R39.
 - Select R40 to give $E_{cmd} = 5.0V_{dc}$ with maximum signal current.
 - Select R24 for desired soft-start time.
 - Factory selected R27.
 - Cut trace for 120° Burst Pulse Profile.
 - Cut trace for soft off.
 - J4 provided for test phase reference inputs.
 - Select R9 resistance for +24V control voltage.
 - Select R10 CT/rectifier burden resistance to give 2.0 Vdc current signal at rated current with 1.0 A maximum CT secondary current.
 - For open loop operation:
 - Omit U3, BR2, BR3, RN6, D3, D4, C14, C15, C23, R10, R11, R35, R38, R39, R40, R41, R43, R44, and R47.
 - Install JU1
 - Install R32 = 150k for 0/5 V cmd, = 249 k for .85 V to 5.85 V cmd.
 - Change R36 to 47.5k.
 - Select R39 to scale the voltage command:
 - R39 = 0 ohm for 0/5 V command
 - R39 = 9.09 kohm for 0/10 V command
 - For 50 Hz operation:
 - Change RN2 to 150k.
 - Remove R28.
 - Current command:
 - For on-board current cmd, install R44 and omit R42.
 - For off-board current cmd, install R42 and omit R44.
 - Install JU2 to connect J3-7 to COM.
 - For use with FCLB-1 Fault Current Limiter Board:
 - Omit BR2 and BR3.
 - Jumper pads 1-2 and 3-4 of BR3
 - Install JU3
 - Typical semiconductor connection diagram:

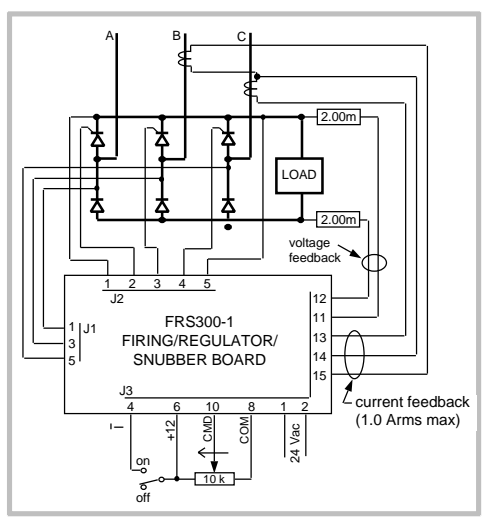

2nd Production Lot 8-31-99

NOTICE: This drawing has not been published and is the sole property of Enerpro, Incorporated. This drawing has been sent to the customer for his confidential use only. In consideration of the use of this drawing, the recipient promises and agrees that it shall not be reproduced, copied, lent or otherwise used in any way detrimental to the interest of Enerpro, Incorporated.

Control Number: 1115-01-5-2-01	ENERPRO	
dwn ppd 11-2-98		
chkd fjb 2-24-99	SEMI-CONVERTER FIRING/ REGULATOR/SNUBBER BOARD	
ECO --	PWB PART NO. FRS300-1	Dwg. no. E1115
VERSION: 8-31-99	SIZE: B	SHEET 1 OF 2

