

PART	PART NUMBER	DESCRIPTION
U1	I134074P	MC34074P
U2	I14077BCP	MC14077BCP
D1 - D3	D1N914B	1N914B
D4	D1N4004	1N4004
R1	R1P93PR502	93PR5K
R2	R1W03W200	SSW-2C 200
R10	R1F1213	RN55 121k 1%
R11	R1F7503	RN55 750k 1%
R12	R1F4991	RN55 4.99k 1%
R13	R1F2492	RN55 24.9k 1%
R14	R1F1002	RN55 10.0k 1%
R15	R1F4991	RN55 4.99k 1%
RN1	R1S101103	R1S101103
RN2	R1S061683	R1S061683
C1	C1TN016106	ECSF16E10
C2	C1TN016106	ECSF16E10
C3	C1TTN035226	Tant. 22 μ F, 35V
C4	C1TN016106	ECSF16E10
C5	C1TN35335	Tant. 3.3 μ F, 35V
C6	C1FL050102	C1FL050102
Q1	T2BS170P	BS170
K1	R3DK1A1B	DK1a1b-24V
J1	C2MSC14	SSW-114-02-S-S
J2	C2MNLVPH03	350789-1
PD1	D1L5381H3	AMBER W /STAND
PD2	D1L5502204G	GREEN W /STAND
COM	W1JCOMM	COM JUMPER
TP1-4	T3TP104	TEST POINT

(J1 interconnects with J6 on FCRO4100, rev. H & later)

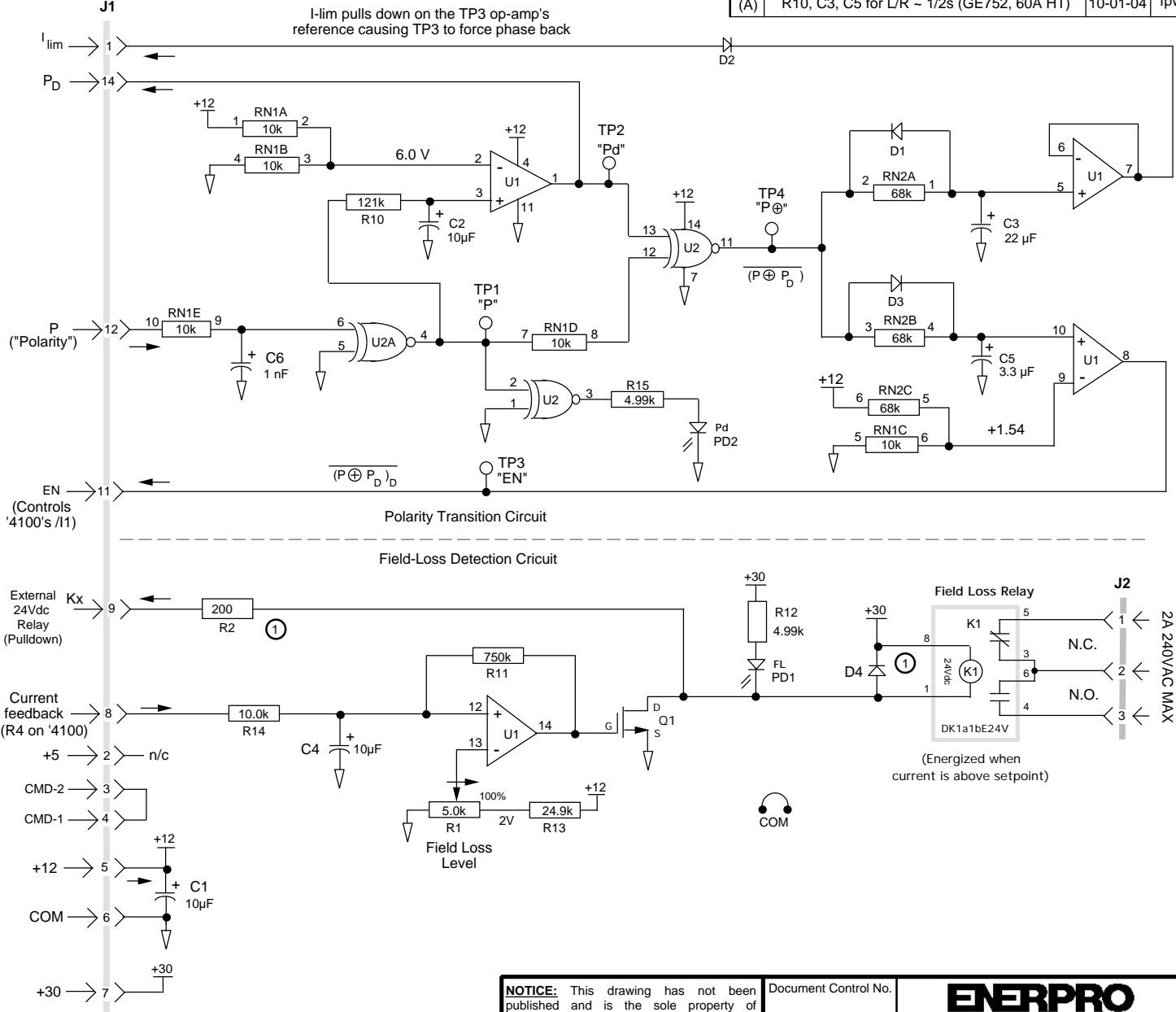

REV	DESCRIPTION	DATE	APPR.
NC	Initial Drawing.	6-18-04	PPD
(A)	R10, C3, C5 for L/R ~ 1/2s (GE752, 60A HT)	10-01-04	fpw

NOTES

- For On-board relay: Install D4, J2, and K1, omit R2.
For External relay: Install R2, omit D4, J2, and K1.
- Relay will be energized when the current is above the setpoint.

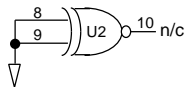

NOTICE: This drawing has not been published and is the sole property of Enerpro, Incorporated. This drawing has been sent to the customer for his confidential use only. In consideration of the use of this drawing, the recipient promises and agrees that it shall not be reproduced, copied, lent or otherwise used in any way detrimental to the interest of Enerpro, Incorporated.

Document Control No.		ENERPRO	
dwn ppd	6-18-04	1Ø TRANSITION INHIBIT CIRCUIT WITH FIELD LOSS RELAY	
chkd fpw		PWB PART NO.	Dwg. no.
ECO	--	PTIFL-1	E1411
VERSION:	10-1-04	SIZE: A	SHEET 1 OF 1